



## OrecX – TDM recording overview

There are two basic ways of recording TDM:

- Station-side Recording
- Trunk-side Recording

### Station-side Recording

A station-side recording configuration requires the ability of the recorder to interface to the existing phones. It is critical to know the model number of your individual phone sets. Call data that can be collected is again specific to your particular switch type and phone set in use. Typically any call data presented to your phone display can be captured and indexed to the call. In most cases this includes dialed number, caller ID, extension, etc). The recording system will provide the date/time/extension and in most cases the agent.

This recording type enables all calls to be recorded that are handled by the extensions connected to the recording system. This includes inbound, outbound and station-to-station calls. Only calls handled by the phones connected to the recording system are recorded. As soon as a call is transferred out of the connected station/agent pool the call is no longer recorded. So you are able to record the internal calls, within the recorded pool, but unable to follow a customer's call transferred out of the recorded pool.

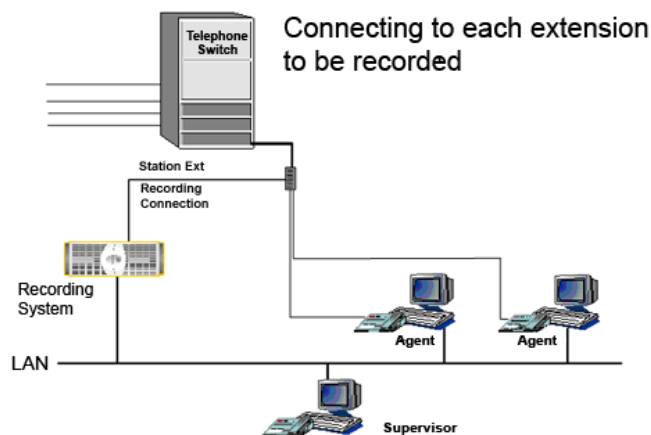

For Station-side recording there are 3 components:

- The server(s), the Voice card(s), the Software Licenses

#### 1. The Server -

- 2.6GHz, 4 MB L2 Cache
- Dual Core (up to 100 concurrent calls)
- Quad Core (101-200 concurrent calls)
- 2 GB RAM
- Two server-grade HD
- Linux (CentOS 4.4)

#### 2. The Voice card(s) – Classic, FULL-Length PCI – NOT PCI-express

- For Analog sets - we recommend Audiocodes SmartWORKS LD.
- For Digital sets - we recommend Audiocodes SmartWORKS NGX.

#### 3. The Software Licenses

- Oreka TR – choose the type of license that best fits your needs (annual subscription, permanent license or server-based license).



## OrecX – TDM recording overview

### Trunk-side Recording

Trunk-side recording is available on any type of switch. Compatibility with the recording system is not an issue. The phone lines (T-1's) deliver some call data. The recording system will not automatically display any metadata other than time of call and call duration. In almost every case the switch can provide additional call data (date/time/extension/agent ID/ dialed number/ANI/DNIS/etc).

This recording type enables all calls to be recorded without investing in a record channel for each phone. For example if you have 2 T-1's delivering up to 48 calls at once and 78 phones, you only need 48 record channels.

Another benefit to this type of recording is the ability to record your entire customers call. You will be able to record all segments of the call. Even if this call is put on hold, transferred to three different agents and then sent to a manager the entire call is captured. The down side to this configuration is no internal calls are recorded. Since the recording system is connected in front of the switch, it doesn't see any of the extension to extension calls.

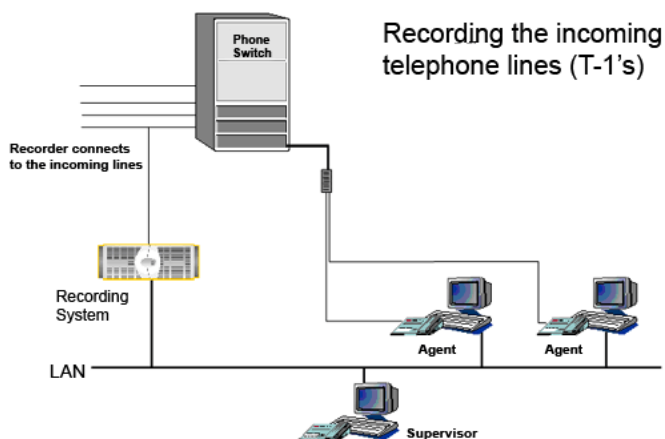

For Trunk-side recording there are 3 components:

- The server(s), the Voice card(s), the Software Licenses

#### 1. The Server -

- 2.6GHz, 4 MB L2 Cache
- Dual Core (up to 100 concurrent calls)
- Quad Core (101-200 concurrent calls)
- 2 GB RAM
- Two server-grade HD
- Linux (CentOS 4.4)

#### 2. The Voice card(s) – Classic FULL Length PCI, NOT PCI-Express

- For Trunk-side recording, we recommend Audiocodes SmartWORKS™ DP for passive tapping of T /E trunks in high-density environments.

#### 3. The Software Licenses

- Oreka TR – choose the type of license that best fits your needs (annual subscription, permanent license or server-based license)

---

One other potentially inexpensive option is the use of Oreka TR with Sangoma's new Wanpipe Voice RTP TAP driver that supports RTP (Real-time Transfer Protocol) tapping. This option is best-suited for companies that have Sangoma hardware already in place. Contact us to discuss this option in greater detail.